

Ultra Back Contact N-type

> 400- 410W

+22.8%

Module efficiency

Module efficiency up to 22.85 %



Elegant design

Cells free from frontal metallization



PID resistance

Certified according to IEC TS 62804 standards



Increased resistance

Certified resistance against salt mist and ammonia



Hail resistance

RG3/HW3 certified



Easy to handle

Comfortable installation thanks to an optimized area size



20

Years

Product Warranty

+5 years for Premium Partners

30

Years

Performance Warranty

Linear Warranty

1% First year degradation

0.25% Annual degradation

91.75% Power in year 30

Light up your world with Eurener

Eurener's extensive portfolio of certifications and awards is testament to our unwavering commitment to our partners and our deep sense of social and ethical responsibility.



Spanish Quality
Worldwide



Awarded as TOP Brand PV
in -FR-SW-BE-UK-



EcoVadis
Platinum Medal



Eurener MEPV — ULTRA 400-410W

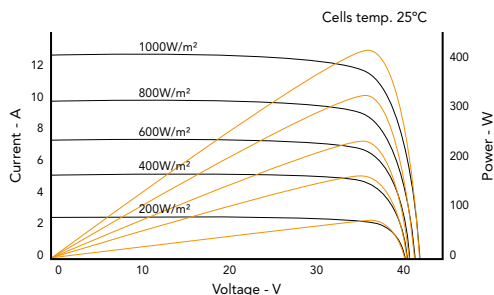
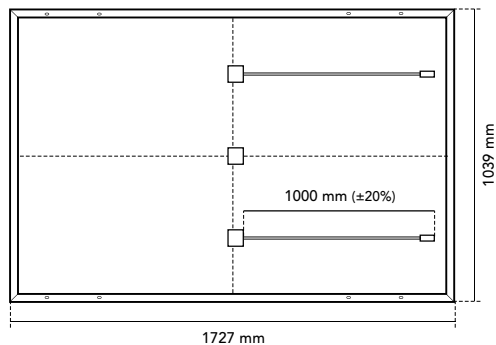

Mechanical Specification	
Solar cells	N-Type monocrystalline silicon cells
Front Glass	3.2 mm thick tempered glass with high strength and ARC
Frame	Black anodized aluminium
Junction Box	IP68, 3 by-pass diodes
Connector	Original MC4-Evo 2
Cable	1000 mm (±20%) length and 4 mm ² section
Dimension	1727 x 1039 x 30 mm (±1%)
Area	1.79 m ²
Weight	20 kg
Packaging	949 pcs/truck

Temperature Coefficients	
Temperature coefficient of Isc (α)	0.045 %/°C
Temperature coefficient of Voc (β)	-0.247 %/°C
Temperature coefficient of Pmax (γ)	-0.29 %/°C
Temperature range	-40 °C ~ +85 °C
Nominal operating cell temperature (NOCT)	43 ± 2 °C

	MEPV 400	MEPV 405	MEPV 410
Electrical Characteristics			
	STC		
Nominal power. Pmax	400 Wp	405 Wp	410 Wp
Short-circuit current (Isc)	12.05 A	12.15 A	12.26 A
Open-circuit voltage (Voc)	42.10 V	42.30 V	42.49 V
Maximum power current (Imp)	11.09 A	11.16 A	11.24 A
Maximum power voltage (Vmp)	36.10 V	36.30 V	36.49 V
Module efficiency	22.31 %	22.57 %	22.85 %
Electrical Characteristics			
	NOCT		
Nominal power. Pmax	307 Wp	311 Wp	315 Wp
Short-circuit current (Isc)	9.72 A	9.80 A	9.88 A
Open-circuit voltage (Voc)	40.23 V	40.43 V	40.63 V
Maximum power current (Imp)	8.96 A	9.02 A	9.08 A
Maximum power voltage (Vmp)	34.23 V	34.43 V	34.63 V

* STC: 1000 W/m², module temperature 25°C, AM 1.5
 * NOCT: 800 W/m², ambient temperature 20°C, AM 1.5

Operating parameters	
Maximum voltage	1500 V
Maximum series fuse rating. Ir	20 A
Power output tolerance	0 - +3 %
Voc and Isc tolerance	± 3 %
Fire rating	Class C (UL 790)
Protection class	Class II (IEC 61140)
Mechanical loads	Front load 5400 Pa, Back load 2400 Pa

Corporate and product certificates
ECOVADIS rating - Platinum Medal (TOP 1%)
Solar Industry Forced Labor Prevention Pledge by SEIA
ISO9001:2015 - Quality Management Systems
ISO14001:2015 - Environmental Management System
WEEE compliance in Germany
PV CYCLE Italy
IEC 61215 - Terrestrial photovoltaic (PV) modules - Design qualification and type approval
IEC 61730 - Photovoltaic (PV) module safety qualification
IEC 61701 - Photovoltaic (PV) modules - Salt mist corrosion testing
IEC 62716 - Photovoltaic (PV) modules - Ammonia corrosion testing
IEC TS 62804 - Photovoltaic (PV) modules - Test methods for the detection of potential-induced degradation
Hail resistance HW3/RG3
Certificate of Factory Production Control (UK) - MCS
Fire reaction class: 1 - LAPI
Assessed by Sundahus



NOTE: Read the safety and installation manual before using the product. This data sheet is not legally binding, Eurener reserves the right of final interpretation. Eurener reserves the right to change the product characteristics and/or specifications without prior notice. The latest versions of all documents can always be found on our website at www.eurener.com.

SINCE
1997
 more than
 energy

eurener.com
 contact@eurenerworld.com
 +34 960 045 515
 Calle Colón, 1-23
 46004, Valencia. Spain

European Experts in Residential modules

Since 1997 our main purpose has been to supply quality and long-lasting photovoltaic modules that allow us and future generations, to continue generating clean energy to take care of our planet.